



## INSTRUCTIONS

### SECURE CERTIFICATE OF INDIAN STATUS (SCIS)

#### APPLICATION FOR ALREADY REGISTERED PERSONS

#### ADULTS (16 YEARS OF AGE OR OLDER), CHILDREN (15 YEARS OF AGE OR YOUNGER) AND DEPENDENT ADULTS

---

### GENERAL INFORMATION

- ▶ This guide is for already registered persons who are submitting an application to obtain the Secure Certificate of Indian Status (form 83-172E).
- ▶ To obtain forms, visit [www.canada.ca/indian-status](http://www.canada.ca/indian-status), or call 1-800-567-9604.
- ▶ To complete the application, you may need to include a [Guarantor Declaration \(form 83-169E\)](#) or a [Statutory Declaration in Lieu of Guarantor \(form 83-170E\)](#).

A guarantor is a person who can confirm the identity of the adult applicant (16 years of age or older) or the identity of the parent or legal guardian who is applying for a child (15 years of age or younger) or a dependent adult. A guarantor must meet the criteria detailed on the Guarantor Declaration form.

If a Guarantor Declaration is needed, you must submit the form with the **signature of the guarantor**.

If an eligible guarantor is not available, the adult applicant or the applying parent / legal guardian must provide two (2) references who can confirm his/her identity. The Statutory Declaration in Lieu of Guarantor must be completed and signed before a commissioner for oaths, notary public or lawyer.

---

### HOW TO SUBMIT THE APPLICATION

#### IN PERSON:

- At the regional office nearest you. As an appointment may be required, it is recommended that you call ahead of time.
- For the list of regional offices, visit [www.canada.ca/indian-status](http://www.canada.ca/indian-status), or call 1-800-567-9604.

#### BY MAIL:

- If you send the application by mail, you must include a Guarantor Declaration form with the **signature** of the guarantor.
- The guarantor must sign and date the photocopies of the front and back of your identity document(s).
- The guarantor must also sign and date the back of one (1) of the two photos and write the statement "this is a true likeness of (name of adult, child or dependent adult)".

Send the application to:

**National SCIS Processing Unit**  
**10 Wellington Street**  
**Gatineau, Quebec K1A 0H4**



### PHOTO SPECIFICATIONS

- ▶ You must provide two (2) identical and unaltered Canadian passport-style photos, taken within the last twelve (12) months of the date of this application.

**Note:** U.S. passport photo specifications do not meet SCIS photo requirements.

The photos must meet the following requirements:

- Photo size: 50 mm wide x 70 mm high (2 inches wide x 2 3/4 inches high).
- The face, from chin to crown of the head, must measure between 31 and 36 mm (1 1/4 inch and 1 7/16 inch).
- Photos must be originals and not taken from an existing photograph.
- Photos must be printed on plain, high quality photographic paper. Heavyweight paper is not acceptable.
- The image must be clear, sharp and in focus. Photos can be in color or black and white.
- Facial features must appear clearly against a white or light-coloured background.
- Photos must be taken with uniform lighting without shadows, glare or flash reflections.
- The photo must show a full front view of the face and top of the shoulders squared to the camera, and centered in the photo.
- The face must show a neutral expression (mouth closed, eyes open and clearly visible).
- Glasses, including tinted prescription glasses, may be worn as long as the eyes are clearly visible and there is no glare on the face or glasses. Sunglasses are not acceptable.
- Hats and other head coverings must not be worn, except for religious or medical reasons. If worn, the hat or other head covering must not cast shadows on the face and the full face must be clearly visible.
- For a child, the photo must show the child's head and shoulders only. Parent's or child's hands must not appear in the photo.
- For newborns, the photo may be taken while the child is sitting in a car seat, as long as a white blanket is placed over the seat behind the child's head.

The following must appear on the back of one (1) photo:

- The name and address of the studio or person who took the photo, and the date the photo was taken (not the date the photo was printed).
- If you are submitting the application by mail, your guarantor must sign, date, and write the statement: "this is a true likeness of (name of adult, child, dependent adult)".

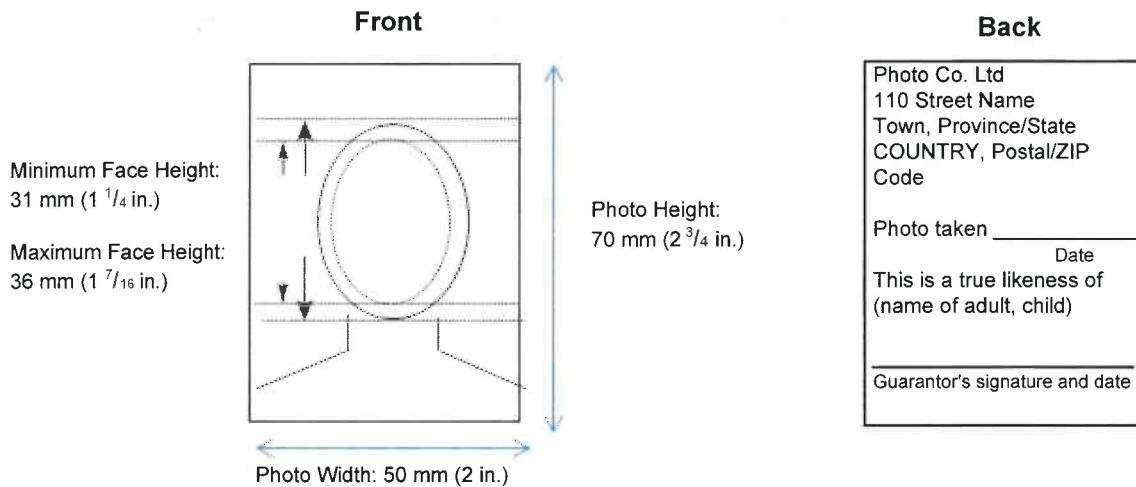

**Image is not the actual size (refer to specified measurements)**



## ADULT (16 YEARS OF AGE OR OLDER) APPLICATION

**Note:** SCIS is the abbreviation for Secure Certificate of Indian Status.

### Instructions for a Simplified Renewal

**If you meet these four (4) conditions:** **1)** you were 16 years of age or older when you last applied for an SCIS; **2)** your personal information has not changed (name and/or band affiliation); **3)** your SCIS has not been revoked or reported lost, stolen, damaged or destroyed; and **4)** this application is made no later than 12 months past the renewal date indicated on your SCIS:

1. Complete sections 1, 3, 5; **please sign and date section 6**; complete section 7, if applicable.
2. Include two (2) Canadian passport-style **PHOTOS** (refer to photo specifications).
3. Include your SCIS as your **IDENTITY DOCUMENT (section 3)**. No other identity document is required.
4. **If submitting the application in person**, it is recommended that you bring your SCIS with you; a photocopy will be made on site and you will retain your SCIS. A photocopy of your SCIS is acceptable if you include a Guarantor Declaration form and the guarantor signs and dates the photocopy of the front and back of your SCIS (recommended if you send the application by mail).

**If submitting the application by mail**, the guarantor must also sign and date the back of one (1) photo and write the statement "this is a true likeness of (your name)".

### Instructions for All Other Adult Applications

1. Complete all applicable sections of the form; **please sign and date section 6**.
2. Include two (2) Canadian passport-style **PHOTOS** (refer to photo specifications).
3. Include your **IDENTITY DOCUMENT(S) (section 3)**. Select ONE of the following five options based on the documents that you have.

Option 1 - ONE (1) document that contains your name, date of birth, photo and signature, among these: **1)** passport; **2)** driver's licence; **3)** Canadian military identification document; **4)** identification card issued by a province or territory; **5)** provincial, territorial or federal Correctional Services identity document (with or without a signature); **6)** health card issued by a province or territory if it shows your name, date of birth, photo and signature; **7)** Canadian citizenship card issued prior to February 1, 2012; **8)** Canadian permanent resident card with signature (issued before February 4, 2012); **9)** U.S. permanent resident card. **Your identity document must not be expired.**

Option 2 - More than one of the following documents that, when combined together, contain your name, date of birth, photo and signature: **1)** health card issued by a province or territory; **2)** government employee identification card; **3)** Canadian permanent resident card without signature (issued after February 4, 2012); **4)** U.S. passport card; **5)** NEXUS or FAST card; **6)** firearms license; **7)** U.S. Old Age Security card. **Your identity documents must not be expired.**

Option 3 - Your Secure Certificate of Indian Status (SCIS) and one (1) identity document listed under option 2 **OR** your SCIS and a Guarantor Declaration form. You may use your SCIS only if this application is submitted no later than 12 months past the renewal date indicated on your SCIS.

Option 4 - Your Certificate of Indian Status (CIS) and one (1) identity document listed under option 2 **OR** your CIS and a Guarantor Declaration form. You may use your CIS only if this application is submitted no later than 6 months past the expiry date indicated on your CIS.

Option 5 - ONE (1) identity document listed under option 2 and a Guarantor Declaration form. The guarantor must sign and date the back of one (1) photo.

**Note:** You may include your original identity document(s) (recommended if submitting your application in person) **OR** a photocopy of the front and back of your identity document(s) and a Guarantor Declaration form (recommended if you send the application by mail). The photocopies must be signed and dated by the guarantor.

4. Include **NAME-LINKING DOCUMENT(S) (section 4)**, if applicable. If you changed your name, a legal document linking your previous name with your current name must be provided, such as a name change certificate, a marriage certificate, a divorce order, or an amended birth certificate with your current name and the names of your parents. If name-linking documents were provided previously, you do not need to provide them again.

You may include an original name-linking document **OR** a photocopy of the name-linking document and a photocopy of a government-issued identity document with your current name (for example, a driver's licence).

5. **If submitting the application by mail**, include a Guarantor Declaration form and follow the instructions on page 1.





## CHILD (15 YEARS OF AGE OR YOUNGER) / DEPENDENT ADULT APPLICATION

**Note:** SCIS is the abbreviation for Secure Certificate of Indian Status.

1. Complete all applicable sections of the form; **please sign and date section 6.**

2. Include the required documents for the child or dependent adult:

- Two (2) Canadian passport-style **PHOTOS** (refer to photo specifications).
- Photocopy of the most recent **LEGAL DOCUMENTS** (such as a divorce judgment, separation agreement, custody or guardianship order) proving custody or guardianship of the child to the applying parent/guardian. If there are legal documents, they must be provided.
- Photocopy of the **ORDER OF GUARDIANSHIP** for the dependent adult.
- **NAME-LINKING DOCUMENT(S) (section 4)**. If the name of the child or dependent adult has changed, a legal document linking the previous name with the current name of the child or dependent adult must be provided, such as a name change certificate or an amended birth certificate with the current name and the names of the parents. If name-linking documents were provided previously, you do not need to provide them again.

You may include an original name-linking document **OR** a photocopy of the name-linking document and a photocopy of a **government-issued** identity document with the current name of the child or dependent adult (for example, a health card).

3. Include the parent's or legal guardian's **IDENTITY DOCUMENT(S) (section 3)**. Select **ONE** of the following five options based on the documents that you have.

Option 1 - Your Secure Certificate of Indian Status (SCIS) if this application is submitted no later than 12 months past the renewal date indicated on your SCIS.

Option 2 - Your Certificate of Indian Status (CIS) if this application is submitted no later than 6 months past the expiry date indicated on your CIS.

Option 3 - ONE (1) document that contains your name, date of birth, photo and signature, among these: **1)** passport; **2)** driver's licence; **3)** Canadian military identification document; **4)** identification card issued by a province or territory; **5)** provincial, territorial or federal Correctional Services identity document (with or without a signature); **6)** health card issued by a province or territory if it shows your name, date of birth, photo and signature; **7)** Canadian citizenship card issued prior to February 1, 2012; **8)** Canadian permanent resident card with signature (issued before February 4, 2012); **9)** U.S. permanent resident card. **Your identity document must not be expired.**

Option 4 - More than one of the following documents that, when combined together, contain your name, date of birth, photo and signature: **1)** health card issued by a province or territory; **2)** government employee identification card; **3)** Canadian permanent resident card without signature (issued after February 4, 2012); **4)** U.S. passport card; **5)** NEXUS or FAST card; **6)** firearms license; **7)** U.S. Old Age Security card. **Your identity documents must not be expired.**

Option 5 - ONE (1) identity document listed under option 4 and a Guarantor Declaration form. The guarantor must sign and date the back of one (1) photo.

**Note:** You may include your original identity document(s) (recommended if submitting your application in person) **OR** a photocopy of the front and back of your identity document(s) and a Guarantor Declaration form (recommended if you send your application by mail). The photocopies must be signed and dated by the guarantor.

4. Include a photocopy of **NAME-LINKING DOCUMENT(S) for the parent or legal guardian (section 4)**, if applicable. If your name as it appears on your identity document(s) is not the same as the name that appears on the legal custody or guardianship documents that you are including with this application, or on documents previously provided to the Department (for example, the child's birth certificate that was provided at the time of his or her registration), you must provide a legal document linking your previous name with your current name. Examples of name-linking documents include: a name change certificate, a marriage certificate, a divorce order, or an amended birth certificate with your current name and the names of your parents. If name-linking documents were provided previously, you do not need to provide them again.

5. **If submitting the application by mail**, include a Guarantor Declaration form and follow the instructions on page 1.



## SECURE CERTIFICATE OF INDIAN STATUS (SCIS)

### APPLICATION FOR ALREADY REGISTERED PERSONS

#### ADULTS (16 YEARS OF AGE OR OLDER), CHILDREN (15 YEARS OF AGE OR YOUNGER) AND DEPENDENT ADULTS

**Privacy Act Statement**

Only information needed to respond to program requirements will be requested. Collection, use, and disclosure of personal information are in accordance with the *Privacy Act*. In some cases, information may be disclosed without your consent pursuant to subsection 8(2) of the *Privacy Act*. The authority to collect and use personal information for the Indian Registration and the Secure Certificate of Indian Status programs is derived from the *Indian Act*. We use the personal information we collect to issue a Secure Certificate of Indian Status to registered persons. We may share the personal information you provide as outlined under Personal Information Bank AANDC PPU110 (Info Source <http://www.aadnc-aandc.gc.ca/eng/1100100011039/1100100011040>). The information collected is retained by the Department for 30 years after the last administrative action and then transferred to Library and Archives Canada (or as described in the Personal Information Bank). You have the right to access the personal information you give us and request changes to incorrect information. If you have questions or wish to notify us of incorrect information, you may call us at 1-800-567-9604. For more information on privacy issues, you can consult the Privacy Commissioner at 1-800-282-1376.

- ▶ **Complete this form online, or write in block letters using black or dark blue ink.**
- ▶ Instructions (83-172IE) to complete the form : visit [www.canada.ca/indian-status](http://www.canada.ca/indian-status) or call 1-800-567-9604.
- ▶ SCIS is the abbreviation for Secure Certificate of Indian Status.

**Reason for Application** (Select ONE option)

- First SCIS
  Renewal  
 Replacement (lost, stolen, damaged SCIS)
  Replacement (changes to personal information)

**SECTION 1: Information on Person to be Issued an SCIS**

<b>Family Name</b>		<b>Given Name(s)</b>	
Family Name at Birth (if different from above)		Alias / Cultural Name (if applicable)	
Sex (as per Birth Certificate) <input type="radio"/> Male <input type="radio"/> Female		Date of Birth (YYYYMMDD)	
Registration Number (10 digits)		First Nation/Band Name	
<b>Permanent Address</b> <input type="checkbox"/> Address is on Reserve			
Number, Street, Apartment, P.O. Box			
City/Town	Province/Territory (Canada) <input type="button" value="v"/>	State (USA) <input type="button" value="v"/>	Postal/ZIP Code
Telephone Number (Daytime)	Telephone Number (Other)	Email Address	
<b>Mailing Address</b> (if different from above)			
Number, Street, Apartment, P.O. Box			
City/Town	Province/Territory (Canada) <input type="button" value="v"/>	State (USA) <input type="button" value="v"/>	Postal/ZIP Code

**SECTION 2: Parent/Legal Guardian Information** (Complete this section **ONLY** if applying for a child or dependent adult.)

<b>Family Name</b>		<b>Given Name(s)</b>	
Family Name at Birth (if different from above)		Registration Number (10 digits) (if applicable)	Date of Birth (YYYYMMDD)

**Relationship to Child/Dependent Adult:**

- Parent     Custodial Parent     Legal Guardian     Other (Specify) \_\_\_\_\_

▶ **If applying for a child:** Are there separation agreements, court orders or legal proceedings pertaining to the custody of the child?

- No     Yes ▶ If yes, provide photocopies of all legal documents.

▶ **If applying for a dependent adult,** include a photocopy of the Order of Guardianship.



**SECTION 3: Identity Document(s) for Adult Applicant or Parent/Legal Guardian** (refer to the instructions)

Document Type	Document Number	Expiry Date (YYYYMMDD) (if applicable)	Name (as it appears on the document)

**SECTION 4: Name-Linking Document(s)** (refer to the instructions)

Name (exactly as it appears on the document)	Document Type

**SECTION 5: Photo and Signature to Appear on the Secure Certificate of Indian Status (SCIS)**

- ▶ Include two (2) unaltered, identical, Canadian passport-style photographs (refer to the instructions for photos).
- ▶ Sign your name inside the box without touching the borders. You may sign with an "X", in syllabics or another language, as long as this is your usual signature. A signature is not required if the SCIS is for a child (15 years of age or younger) or dependent adult.



**SECTION 6: Declaration and Signature**

- ▶ Failing to sign and date the declaration will delay the processing of your application.
- ▶ Notice to Applicants: The Secure Certificate of Indian Status (SCIS) remains at all times the property of the Government of Canada and must only be used by the person in whose name it is issued. Any false or misleading statement with respect to this application and any supporting document, including the concealment of any material fact, selling or permitting the use of your SCIS by any other person or agency, is cause to revoke or refuse to issue an SCIS, and may lead to criminal prosecution.

**Declaration:** I solemnly declare that all statements made in this application are true, all documents provided to support this application are unaltered, and the enclosed photographs are a true likeness of me or the child / dependent adult. I have read and understand the Notice to Applicants and the *Privacy Act* Statement.

I request that \_\_\_\_\_, if eligible, be issued a Secure Certificate of Indian Status.  
(Print Name of Adult, Dependent Adult or Child)

If applying to replace a lost, stolen, damaged or destroyed SCIS: I declare that I have not given my Secure Certificate of Indian Status (SCIS) to another person or disposed of it in an unauthorized manner. I understand that an SCIS reported lost, stolen, damaged or destroyed is no longer valid and can no longer be used. Should I regain possession of my SCIS, I understand that I am to destroy it immediately.

<b>Signature of Adult Applicant (16 years of age or older) or Parent/Legal Guardian</b>	Date (YYYYMMDD)
X	

**SECTION 7: Indian Registration Administrator (IRA)**

- ▶ If an IRA assisted in completing this form, he or she must complete and sign this section.

Name	First Nation/Band Number or Initiator Code	IRA Signature	Date (YYYYMMDD)
		X	





## REGISTRATION AND SECURE CERTIFICATE OF INDIAN STATUS (SCIS) GUARANTOR DECLARATION

### Privacy Act Statement

This statement outlines the purposes for the collection and use of personal information. Only information needed to respond to program requirements will be requested. Collection, use, and disclosure of personal information are in accordance with the *Privacy Act*. In some cases, information may be disclosed without your consent pursuant to subsection 8(2) of the *Privacy Act*. The authority to collect and use personal information for the Indian Registration and the Secure Certificate of Indian Status programs is derived from the *Indian Act*. We use the personal information we collect to determine entitlement to registration on the Indian Register and membership in a First Nation for which the Band List is maintained by the Department, to issue a Secure Certificate of Indian Status to registered persons, and for the provision of benefits and services conferred exclusively to those who are registered. We may share the personal information you provide as outlined under Personal Information Bank AANDC PPU110 (Info Source <http://www.aadnc-aandc.gc.ca/eng/1100100011039/1100100011040>). The information collected is retained by the Department for 30 years after the last administrative action and then transferred to Library and Archives Canada (or as described in the Personal Information Bank). As stated in the *Privacy Act*, you have the right to access the personal information you give us and request changes to incorrect information. If you have questions or wish to notify us of incorrect information, you may call us at 1-800-567-9604. For more information on **privacy issues and the *Privacy Act*** in general, you can consult the Privacy Commissioner at 1-800-282-1376.

► **Complete this form online, or write in block letters using black or dark blue ink.**

### Applicant Information

► For the purposes of this form, the applicant is the adult (16 years of age or older) applying for registration and/or for the Secure Certificate of Indian Status (SCIS), or the parent/legal guardian applying for a child (15 years of age or younger) or dependent adult.

Family Name	Given Name(s)	
Alias / Cultural Name (if applicable)	Date of Birth (YYYYMMDD)	Registration Number (10 digits) (if applicable)
I certify that I am the person (applicant) named above	Signature of Applicant	Date (YYYYMMDD)
	<b>X</b>	

### Name of Child/Dependent Adult (if applicable)

Family Name	Given Name(s)
-------------	---------------

### Guarantor Information and Declaration

Family Name	Given Name(s)
-------------	---------------

### Permanent Address

Number, Street, Apartment, P.O. Box

City/Town	Province/Territory (Canada)	State (USA)	Postal/ZIP Code
-----------	-----------------------------	-------------	-----------------

SCIS Serial Number (on the back of the card)	Occupation (if guarantor does not have an SCIS)
--	---

Applicant known for _____ years (minimum 2 years)	Telephone Number (Daytime)	Name of Firm/Organization (if applicable)
---	----------------------------	---

**Instructions for guarantor:** As needed, you must **sign** and **date** the photocopies of the front and back of the documents that support the applicant's identity. You must also **sign, date** and **write** the statement "This is a true likeness of (name of applicant or child or dependent adult)" on the back of **one (1)** of the two photographs.

**I solemnly declare** that I am at least 18 years of age and have known the applicant named above personally for at least **two (2)** years. I have signed and dated the back of one photo and confirm that the image is a true likeness of the applicant, child or dependent adult, (if a Secure Certificate of Indian Status is requested). I have signed a photocopy of the front and back of each document to support the applicant's identity and confirm that I have seen the original document(s). I understand that any false or misleading statement relating to this form and any document in support of the application, including the concealment of any material fact, may be grounds for criminal prosecution.

Signature of Guarantor

Date (YYYYMMDD)

**X**



## REGISTRATION AND SECURE CERTIFICATE OF INDIAN STATUS (SCIS) GUARANTOR DECLARATION

### GENERAL INFORMATION

A guarantor is a person who can confirm the identity of the applicant.

**Family members** may act as guarantors **only** if they meet all the criteria listed below.

A **parent or legal guardian** applying for registration or for the Secure Certificate of Indian Status (SCIS) on behalf of a child or dependent adult **cannot act as guarantor** for the child or dependent adult.

**The guarantor must perform the following tasks, as needed, free of charge:**

- Complete and sign the Guarantor Declaration form.
- Sign and date the photocopies of the front and back of the applicant's identity documents.
- Sign and date the back of one (1) of the applicant's Canadian passport-style photographs, and write the following statement: "This is a true likeness of (name of applicant or child or dependent adult)."

### CRITERIA

#### The guarantor:

- Must be 18 years of age or older.
- Must reside in Canada or the United States.
- Must be reachable for verification by the Department.
- Must have known the applicant personally **for at least two (2) years**.

**Note:** To know the applicant personally means that the guarantor is able to confirm information about the applicant, such as the name, approximate age, place of birth, physical description and some personal history such as place of residence.

#### The guarantor must be someone from the following list:

- Holder of a valid SCIS (who was 16 years of age or older when he/she applied for the card)
- Indian Registrar or Deputy Registrar
- Elected or appointed official (Band chief or councillor, **Indian registration administrator**, mayor, member of Parliament/Legislative Assembly)
- Medical professional (dentist, medical doctor, optometrist, pharmacist, chiropractor or registered nurse)
- Judge, magistrate or police officer (First Nations; RCMP; municipal, provincial, territorial police)
- Lawyer, notary public
- Minister of religion
- Postmaster/postmistress
- Senior university/college/school administration official and professor/teacher
- Professional accountant
- Professional engineer
- Registered social worker or social service worker
- Military personnel (only for Regular Force members and their dependents)
- Other occupations: visit [www.canada.ca/indian-status](http://www.canada.ca/indian-status) for a more detailed list.

If an eligible guarantor is not available, the applicant must complete the Registration and Secure Certificate of Indian Status Statutory Declaration in Lieu of Guarantor (form 83-170E), and provide **two (2)** references who are not relatives.

#### The references:

- Must be 18 years of age or older.
- Must reside in Canada or the United States.
- Must be reachable for verification by the Department.
- Must have known the applicant personally **for at least two (2) years**.

**Note:** The Statutory Declaration in Lieu of Guarantor (form 83-170E) must be completed and signed before a Commissioner for Oaths, notary public or lawyer.